

Designed for heavy applications and harsh conditions

FPT Industrial manufactures a range of Tier 4F/Stage V engines from 37 kW to 450 kW. FPT Industrial integrates a maintenance-free filtering device on its SCR catalyst, complying with the most stringent emissions regulations worldwide, while keeping a compact package. The second generation HI-eSCR 2 maintains the same after-treatment dimension of the current Tier 4 Final applications, requiring no machine redesign or layout changes to upgrade to the next emission level. Optimized combustion, high performance and fuel efficiency paired with a maintenance-free after-treatment system ensures low running costs, less downtime and reliability.

KEY FEATURES:

- Pre-packaged and pre-validated ATS for easy installation
- ATS “for life” HI-eSCR2 technology maximizes uptime and reduces operating costs
- Dual-certified, Tier 4F/Stage V (avoid layout changes)
- Easy maintenance with single-side access
- Best-in-class 600-hour service interval maximizes uptime
- Flexible configurations to meet your needs

Tier 4F/Stage V – G-Drive Engines Portfolio

Engine Model	kW/HP	Cylinder Arrangement Air Intake	Injection System	Displacement (Liters)	Emission	Exhaust System	Exhaust System	60 Hz / 1800 rpm	
								Stand-by Power	Prime Power
								kWe	kWe
F34	37/49	4L/TC	ECR	3.4	Stage V / Tier 4F	EGR+DOC+DPF	DOC+DPF	33	30
F34	55/74	4L/TC	ECR	3.4	Stage V / Tier 4F	EGR+DOC+DPF	DOC+DPF	42	38
F34	55/74	4L/TCA	ECR	3.4	Stage V / Tier 4F	EGR+DOC+DPF	DOC+DPF	47	46
F36	71/95	4L/TCA	ECR	3.6	Stage V / Tier 4F	EGR+DOC+DPF+SCR	HI-eSCR2	60	54
F36	94/126	4L/TCA	ECR	3.6	Stage V / Tier 4F	EGR+DOC+DPF+SCR	HI-eSCR2	82	74
F36	105/141	4L/TCA	ECR	3.6	Stage V / Tier 4F	EGR+DOC+DPF+SCR	HI-eSCR2	92	92
N67	175/235	6L/TCA	ECR	6.7	Stage V / Tier 4F	DOC+SCRoF	HI-eSCR2	153	138
N67	230/308	6L/TCA	ECR	6.7	Stage V / Tier 4F	DOC+SCRoF	HI-eSCR2	206	186
C87	292/392	6L/TCA	ECR	8.7	Stage V / Tier 4F	DOC+SCRoF	HI-eSCR2	265	240
C87	338/453	6L/TCA	ECR	8.7	Stage V / Tier 4F	DOC+SCRoF	HI-eSCR2	304	276
C13	411/551	6L/TCA	ECR	12.9	Stage V / Tier 4F	DOC+SCRoF	HI-eSCR2	360	325
C13	450/603	6L/TCA	ECR	12.9	Stage V / Tier 4F	DOC+SCRoF	HI-eSCR2	400	362

FPT Tier 4F/Stage V engine are dual-certified (60Hz / 1800rpm to 50Hz/ 1500 rpm)

Legend

Cylinder Arrangement

L In line

Air Intake

TCA Turbocharged Aftercooler
TC Turbocharged

Exhaust System

DOC Diesel Oxidation Catalyst
DPF Diesel Particulate Filter
HI-eSCR2 FPT Industrial's patented system
SCRoF Selective Catalyst Reduction on Filter
SCR Selective Catalyst Reduction

Injection System

ECR Electronic Common Rail

Emission Regulation

Stage V / Tier 4 Final

Engine Family

F = F5
N = NEF
C = CURSOR

NEF 67 Stage V G Drive

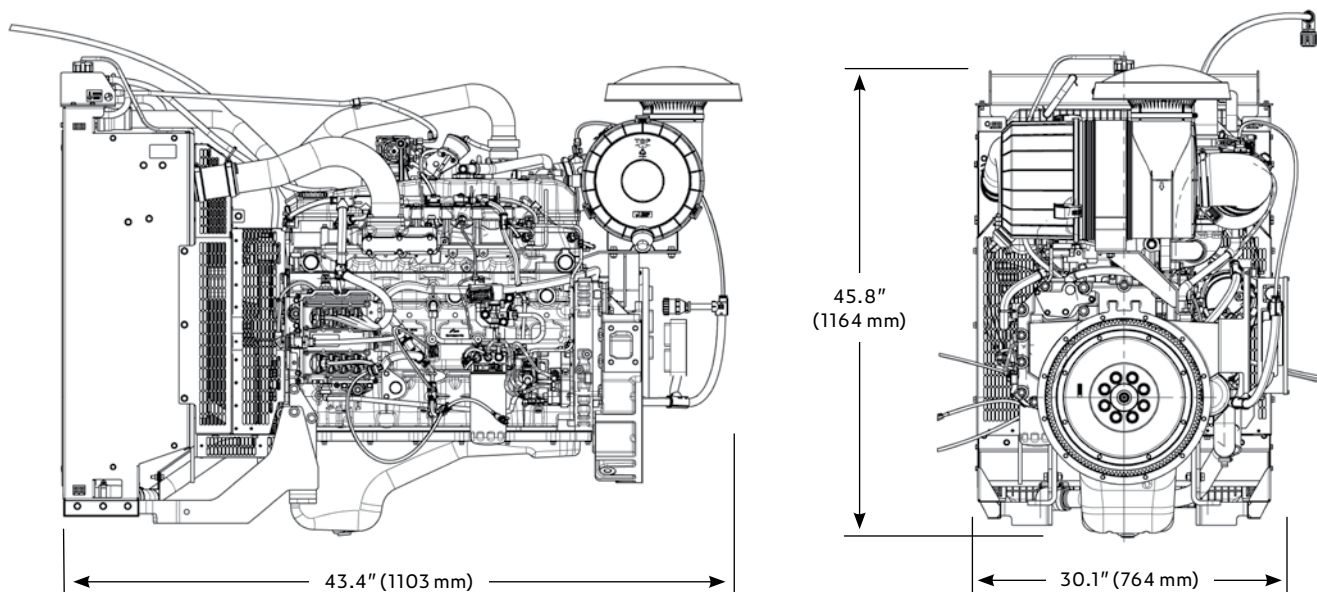

Exhaust Flap

Our patented electronically controlled exhaust flap maximizes performance at low temp, low load, avoiding the need for additional load banks. Improved exhaust gas temperature control to speed up SCR light-off in the cold part of emission cycle through an electronically controlled exhaust flap.



ATS Power Pack - Smart Installation Package

The ATS Pack includes all key after-treatment components in a single package: main catalysts and their relative sensors are included in a compact and pre-assembled set that requires no dedicated design or installation of ATS components. The pre-packed ATS solution has a pre-validated design in order to make the final validation process seamless, including a single electrical cable for fast, reliable and quick connection to any engine.

